



The Leading Manufacturer of Premium Detention Hardware & Accessories



NW SecurityBar[®] *for Correctional and Healthcare Facilities*

Eliminating Ligature Attachment Points and Space for Hiding Items

Outstanding Features

- Suicide Resistant, No Space Between Wall and Bar
- End Caps for Anti-Ligature Solution
- Vertical or Horizontal Installation
- Custom Lengths or L-Corner Bars Available
- Self-Draining for Wet Application
- Handrail to Allow a Full Grip
- Suitable for Continuous Handrail
- Open for Contraband Inspection
- Variable Fastener Spacing for Easy Retrofits
- Specially Hardened Aluminum Alloy
- Clear Anodized Surface
- 100% Made in the U.S.A.

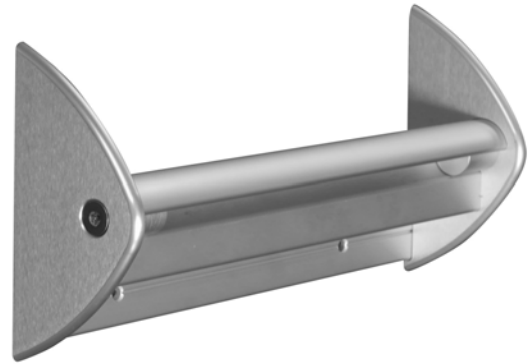

Northwest Specialty Hardware, Inc.
15865 SE 114th Avenue, Suite C
Clackamas, OR 97015
Phone (503) 557-1881 Fax (503) 557-1885 Email: sales@northwestsh.com

www.northwestsh.com

NW SecurityBar® Description

Application: NW SecurityBar® is required to be installed around toilet, tub, or shower stall to provide assistance for persons with disabilities or mobility impairment. The unique design meets the anti-ligature requirements of ADAAG (Americans with Disabilities Act Accessibility Guidelines). The one piece design resists abuse and does not offer a place to conceal contra-band.

To facilitate retrofit installations, NW SecurityBar® is not pre-drilled for fasteners, while it offers a continuous mounting surface. This allows adaptation to a variety of mounting conditions where backing, which is critical for proper attachment, may not align with conventional grab bar mounting points. NW SecurityBar® is applied to behavioral health facilities, hospitals, or correctional facilities.

Materials: NW SecurityBar® is extruded from 6063-T5 aluminum alloy and received a special treatment with a clear anodized surface. Self-draining end caps are installed for anti-ligature and wet application.

Available Sizes: NW SecurityBar® is available from stock in lengths of 18", 24", 30", 36", 42", 48", 54" and 60". Custom lengths or L-Corner bars are available upon special orders.

Competitive Advantages: (1) Cost Advantage Northwest is the leading manufacturer and supplier of premium detention hardware and accessories. Northwest is able to create a cost advantage but maintain the premium quality of anti-ligature healthcare products.

(2) Utilization and Specifying Northwest has been manufacturing and distributing NW SecurityBar® since 2003. NW SecurityBar® is accepted by the New York State Office of Mental Health and listed in the Design Guide of the National Association of Psychiatric Health Systems (NAPHS). NW SecurityBar® is specified by architects and accepted by facilities.

Installation:

1. Determine installation height and location. Locate appropriate backing locations and transfer layout to NW SecurityBar®. Drill holes 1/32" larger than fastener diameter, 3/4" from bottom of the mounting flange.
2. Before securing bar to wall apply a continuous bead of acrylic latex sealant to back of mounting flange, both top and bottom. Secure to wall and wipe away any excess sealant with a moist cloth. (Note: For security applications, epoxy sealant is recommended.)

Maintenance: Normal cleaning with a dry cloth or non-acidic detergent is applied to NW SecurityBar® maintenance.

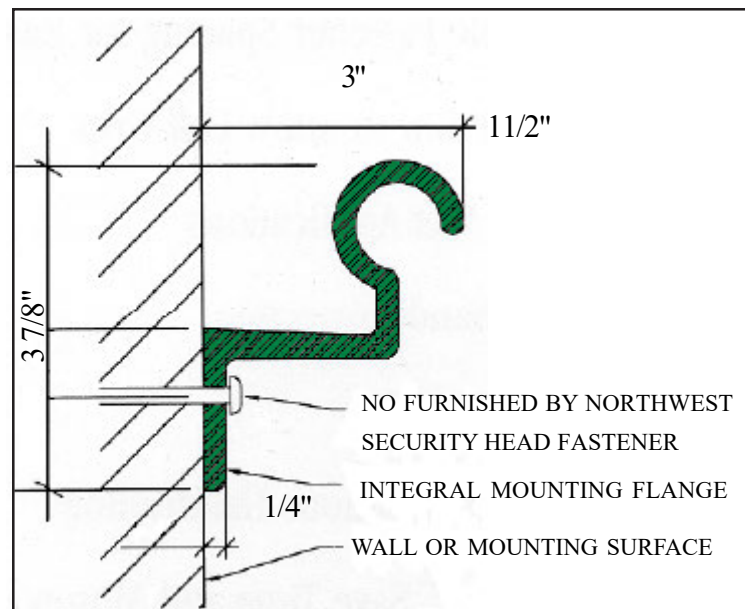

Specifications: NW SecurityBar® shall be manufactured and distributed by Northwest Specialty Hardware Inc.. Special one piece configuration with the following specifications:

1. Material: Extruded 6063-T5 aluminum alloy.
2. Finish: Clear anodized surface.
3. Sizes: Reference drawings for lengths and configurations.
4. End Caps: Self-draining end caps are installed for anti-ligature solution and wet application.